

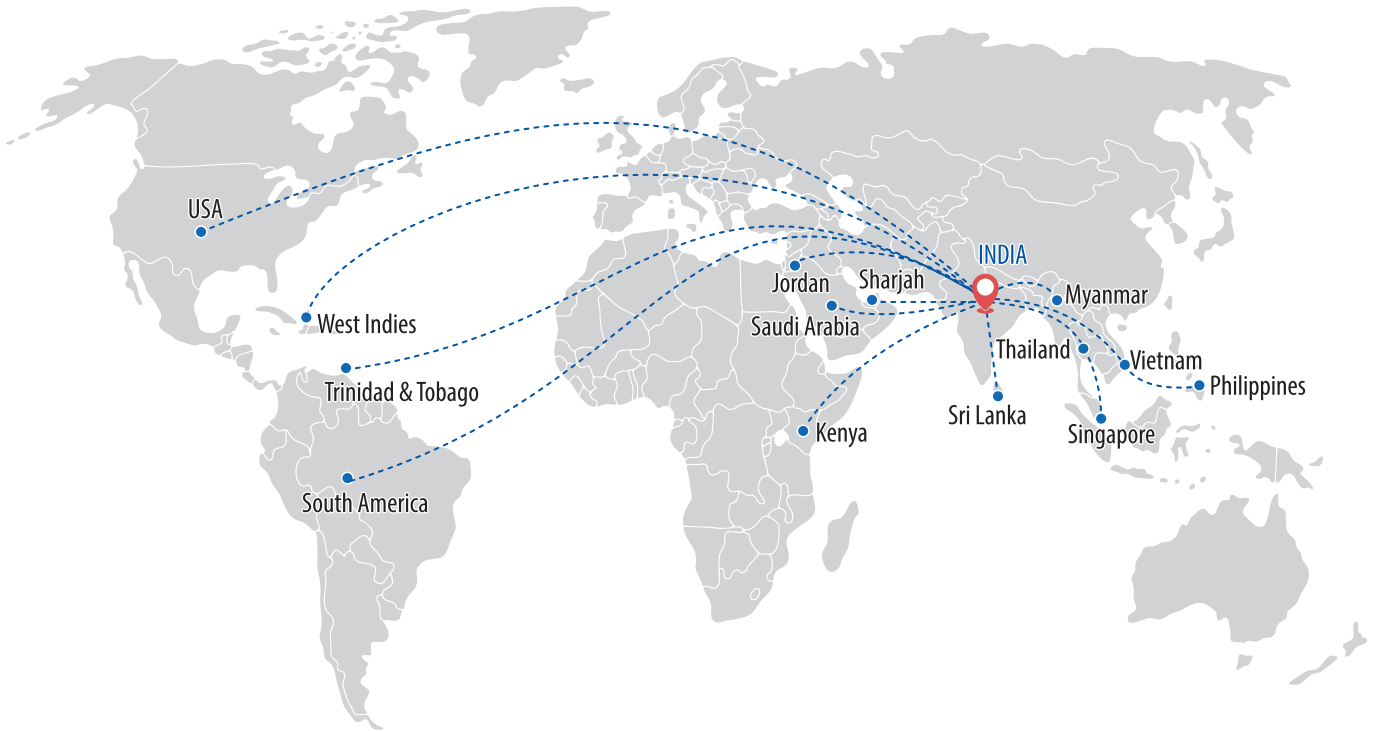

Micro Transmission Systems

Engineers & Manufacturers

Foot Print of our State of the Art Products



About Us

Micro Transmission Systems (MTS) is a reputed manufacturer of water and wastewater treatment solutions. The firm was founded in 1996 to serve engineering industry and later on we moved to serve water/ waste water treatment industry as per growing need of society and worldwide scarcity.

MTS is headquartered in Greater Noida and has a state-of-the-art in-house manufacturing facility well-equipped with ISO 9001:2015, 14001:2015, and 45001:2018 certified Quality Management Systems. Our products enjoy a stellar global reputation due to the high manufacturing and incomparable service quality. MTS takes pride in its employees' enduring efforts, unmatched skills, and unwavering commitment.

Our group company M/S beta Maschinenfabrik Pvt. Ltd. is a pioneer in manufacturing high-quality root blowers. The firm is an established name in the water and wastewater industry globally.

Both companies are ISO 9001:2015 certified and known for their product quality, competitiveness, efficiency, and energy-saving solutions. This is achieved by implementing all aspects of quality control procedures to obtain the national (ISI) and international (ISO) quality standards.

At MTS, we always strive for our customers' delight. It is a firm belief at MTS that our customers should be provided with excellent after-sales services, we achieve this through our highly specialized and skilled support team.



BAR SCREEN – MULTI RAKE TYPE

Micro Screens is a heavy-duty multi-rake screen provided with inclined bars spaced apart to prevent medium and large floating wastes from travelling further to the pumps located in the pumping station. The range of bar spacing can vary from 12mm to 50mm depending upon application of screen with suitable for channel depth upto 20 mtrs. And width upto 2.2 mtrs.

Material of Construction: SS304/SS316



BAR SCREEN – STEP TYPE

Micro step screen is hydraulically operated Step screen provided with 2 & 3 mm thick equally spaced inclined lamellas to prevent fine sized floating debris from travelling further in to the water and waste water treatment plants. The range of bar spacing can vary from 2mm to 6mm depending upon application of screen with suitable for channel depth upto 1.85 mtrs. And width upto 1.6 mtrs.

Material of Construction: SS304/SS316

J TYPE – TRASH SCREEN

A J-Type Screen commonly known as Trash Screen installed at 90° (vertical) is a coarse screen placed in the inlet channel of STP/CETP/ETP/WTP where space is limited or where a vertical civil slot is already provided.

Bar material: SS 304 / SS 316

Bar spacing: typically, 20–50 mm (coarse screening)

Mounting: Rigid side frames with anchor bolts in civil wall

Orientation: 90° vertical installation

Operation: Manual/ Motorised Lifting Arrangement.



BACK RACK SCREEN

A Mechanical Back Rake Screen is a heavy-duty coarse screen with an automated coarse screening system installed in the inlet channel of STP/CETP/ETP/WTP. It uses a motor-driven rake carriage that travels along the downstream (back) side of an inclined bar rack, engages the trapped debris on the upstream face, and lifts screenings to the discharge point without manual effort.

Best Suitable for big size Channels/ Nallah/ Canals and I&D Tapings

MOC: SS 304 / SS 316

Bar Spacing: 20–60 mm spacing

Inclination: typically, 70°–80°

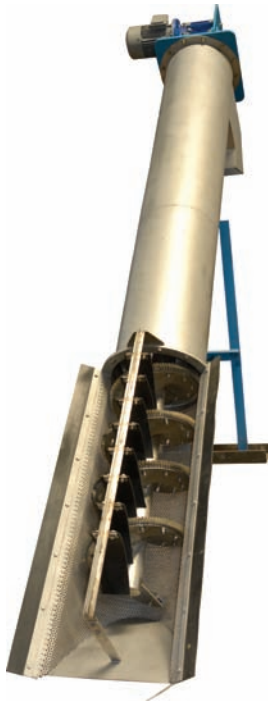

SCREW SCREEN

Micro Screw Screen are intended from medium and small solids from effluent channel and recommended to be used at waste water treatment plants.

Suitable for channel depth upto 4mtrs. And width from 200mm to 600mm

The perforated sheet provides high efficiency of filtration and screw is equipped with a brush on its edges to ensure cleaning of screen media in filtration zone. The trash retaining screen is made of stainless steel in the form of perforated sheet / wedge wire screen and has larger area for filtration due to inclination in effluent channel. Waste retained on the filtering screen are removed by axially rotating screw conveyer up to waste bin.

DRUM SCREEN [out to in]

These Screens are being used for screening of very small size solid waste water like food waste, feather / meat trimmings, fibre, hair etc. The complete screens are made from stainless steel and non-corrosive material for long service life. The filtering screen is made of wedge wire screen that ensures very fine filtration high quality of mesh cleaning is ensured by mounting of non-metallic/ Rotary Brush scrapper on drum screen.



DRUM SCREEN [in to out]

These Screens are being used for screening of very small size solid waste water like food waste, feather / meat trimmings, fibre, hair etc. The complete screens are made from stainless steel and non-corrosive material for long service life. The filtering screen is made of wedge wire screen that ensures very fine filtration high quality of mesh cleaning is ensured by mounting of non-metallic scrapper on drum screen.

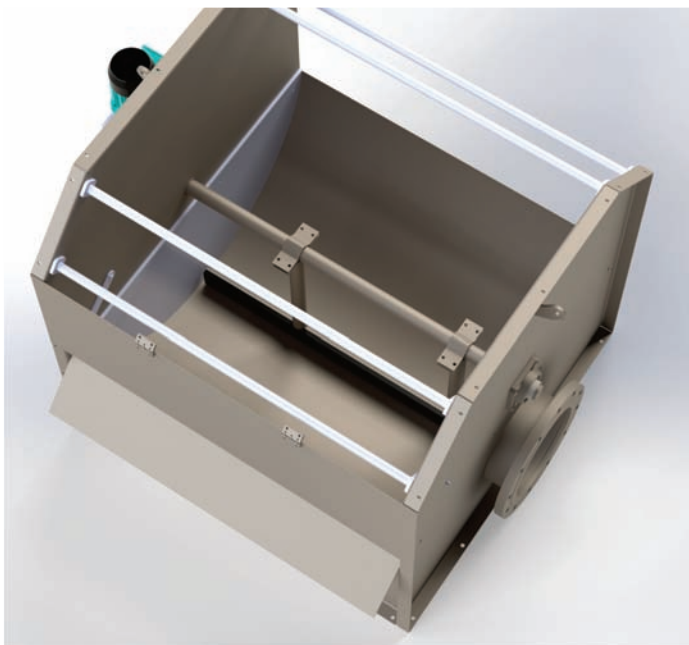
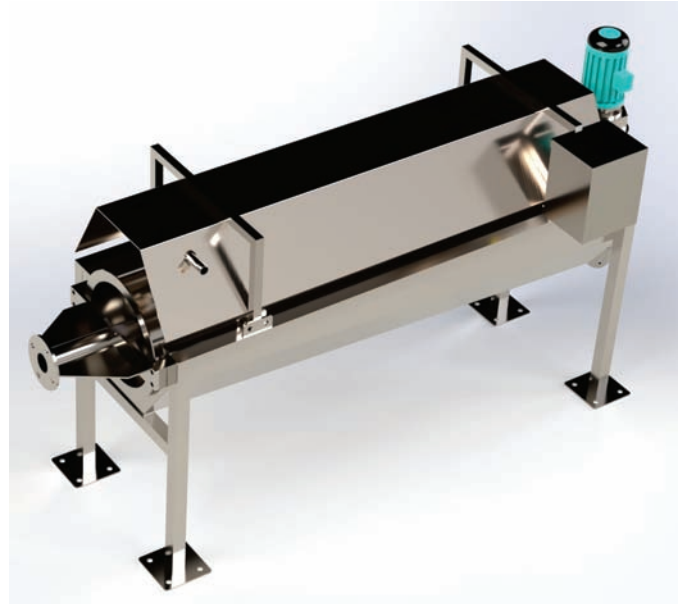

HALF DRUM SCREEN

These Screens are being used for screening of very small size solid waste water like food waste, feather / meat trimmings, fibre, hair etc. The complete screens are made from stainless steel and non-corrosive material for long service life. The filtering screen is made of wedge wire screen that ensures very fine filtration high quality of mesh cleaning is ensured by mounting of non-metallic scrapper on drum screen.

BASKET SCREEN

This screen can be installed in a Manhole prior to pumps, the size depending on the inflow rate and depth. The sturdy, stable basket screen retains the floating debris at the sewer outlet. The screen bottom plate is perforated to allow static dewatering of the retained material. When a certain amount of material has accumulated, the screen basket is lifted upwards by an electric hoist. The vertical basket movement is supported by a stable carrier and guide rails. These rails are curved in the upper section to ensure a partly automatic discharge into a suitable container. Control of screen can be either manual or electrical.

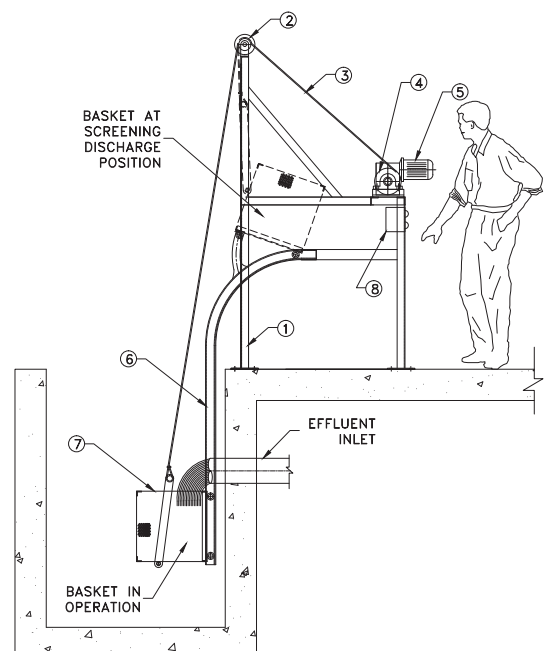

SLUICE GATES – WALL MOUNTED

Deep Gates are expertly designed for handling the task of seating and unseating head pressures with precision and efficiency. These specialized gates are meticulously crafted to provide a secure and reliable solution for controlling the flow of fluids or gases, especially in high-pressure environments. With their robust construction and advanced features, Deep Gates offer unparalleled performance and durability, making them ideal for critical applications where accuracy and consistency are paramount.

- **Low Pressure gates** (with or without thimble)
- **High Pressure gates** (with or without thimble)

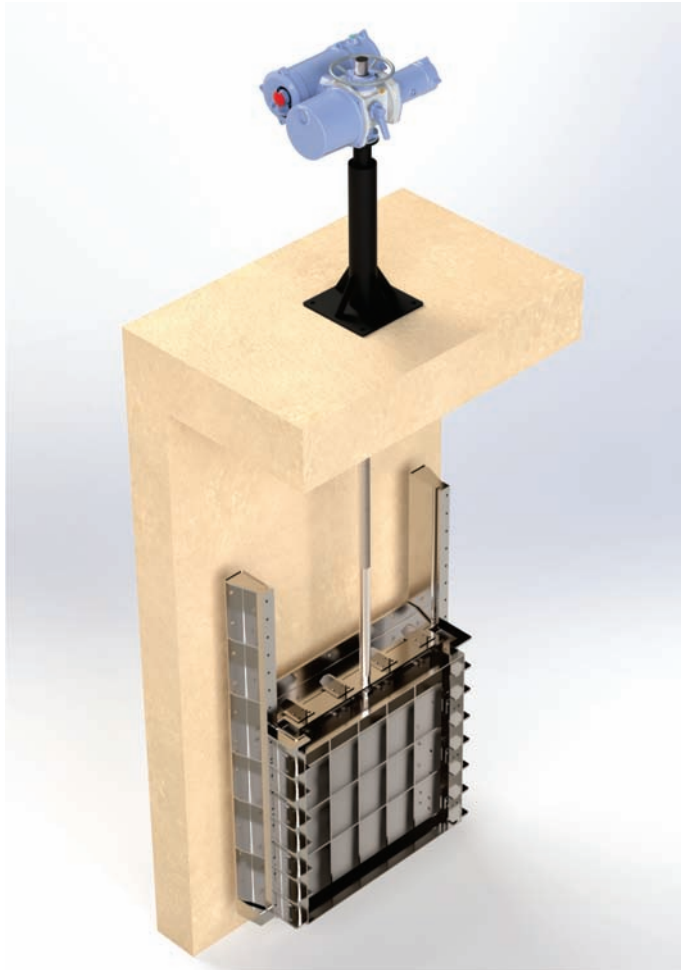

SLUICE GATES – OPEN CHANNEL

Open Channel Sluice Gates are vital infrastructure used to control the flow of water in open channels, such as canals and rivers. These gates can be operated manually or automatically to regulate water levels and prevent flooding during heavy rainfall. By opening or closing the gates, water flow can be managed efficiently to ensure a smooth and controlled movement. These gates play a crucial role in managing water resources and protecting surrounding areas from water-related hazards

- **Channel Mounted**
- **Stop Log gates**

VORTEX GRIT MECHANISM

The Micro Vortex Grit Mechanism is an advanced grit removal system installed at the inlet works of STP, CETP, ETP, and WTP plants to efficiently separate heavy inorganic particles from incoming wastewater before it reaches pumps, screens, aeration tanks, and other mechanical equipment.

Unlike conventional horizontal grit channels, this system operates on a controlled vortex (circular) flow principle within a cylindrical chamber. Wastewater enters the chamber tangentially, creating a rotational flow pattern (vortex). Due to centrifugal action, heavier inorganic grit particles settle at the bottom of the chamber, while lighter organic matter remains in suspension and exits with the treated effluent.

This mechanism ensures high grit separation efficiency, compact footprint, low head loss, and minimal maintenance, making it ideal for modern wastewater treatment facilities.

Working Principle

- Wastewater enters tangentially, creating a vortex flow.
- The rotational motion causes centrifugal action.
- Heavier grit particles lose velocity and settle into the bottom hopper.
- Organic matter stays suspended and exits with the outlet flow.
- Settled grit is removed via grit pump to a Hydro cyclone following Grit classifier.
- The classifier separates water from grit and discharges dry grit to a bin.
- Micro Vortex Grit Mechanism is an efficient, compact, and reliable method for removing abrasive inorganic particles from wastewater by using controlled vortex hydraulics. It significantly reduces equipment wear, improves downstream performance, and is widely adopted in modern treatment plants.

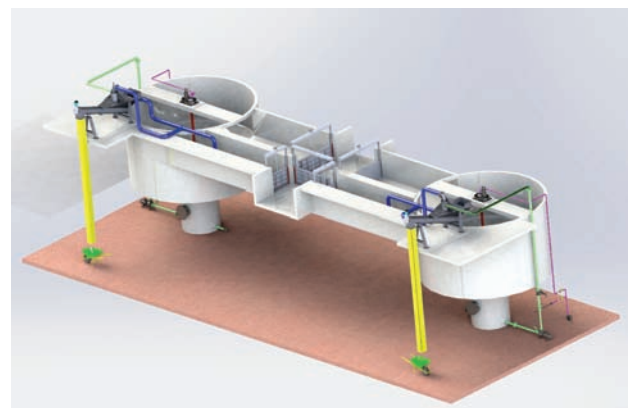
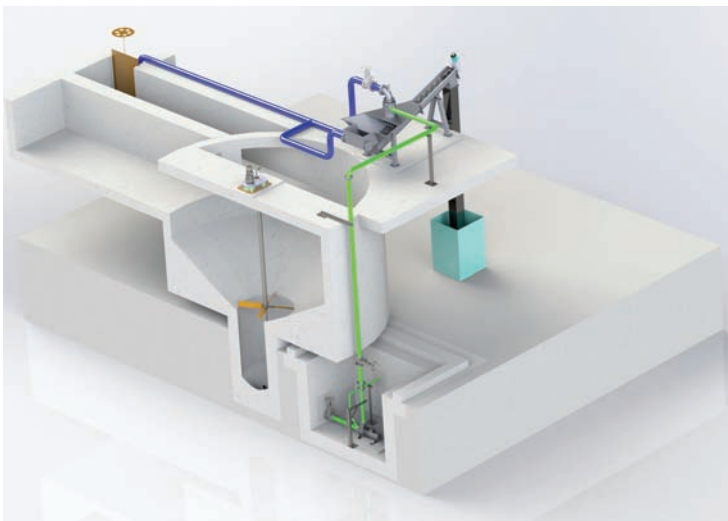

GRIT SEPARATOR MECHANISM - Conventional Type.

The grit removal consists of two essential elements- grit collecting mechanism and grit washing mechanism. Each operates separately but in hydraulic communication with each other.

The Detritors is a continuous flow tank in which the grit settles due to gravity and the water overflows through the outlet weir on the opposite side. The settled grit is scrapped by means of a scraper mechanism towards the openings on the classifier sidewall at the bottom.

The collection chamber works on velocity principle and is so designed that only grit settles down and organic matter overflows. The classifier mechanism consists of a reciprocating rake/screw driven by a gear drive fitted with a motor. The grit collected is given a thorough washing and is delivered from the top of the classifier through a chute for further disposal. The Organic Return Pump / Mixer returns the washed organic liquor lying in the classifier back to the Detritors collection chamber.

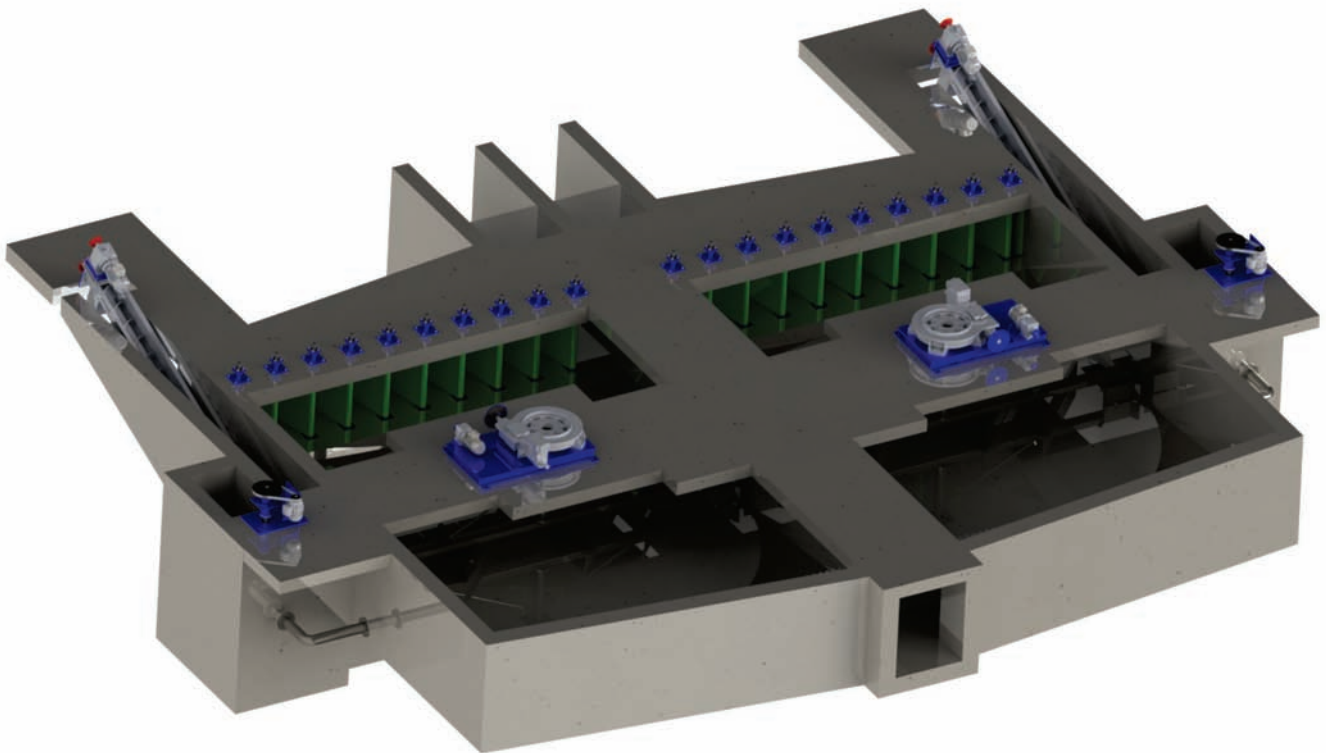

MIXER/AGITATOR

Micro Agitators provide agitation for treating process liquids, water, or wastewater in circular or square tanks. Available in 1 to 25 HP for chemical mixing and blending coagulants, neutralization, and general-purpose mixing. When used for flocculation, the unit has extremely high circulation capacity up to 25 times the feed rate.



STATIC MIXER

A static mixer is an inline device used to mix fluids continuously without moving parts. It relies on fixed, internal elements to create turbulence and achieve thorough mixing.

Key Features: No Moving Parts, Energy Efficiency, Low Maintenance and Consistent Mixing.



CLARIFIER/CLARIFLOCCULATOR

Central feed and Peripheral Flow Clarifiers clarification is the oldest and most widely used operation in the effective treatment of wastewater. Mechanical Clarifiers in the activated sludge process serve a dual purpose. First to provide a clarified effluent and second to provide concentrated source of return sludge for maintaining process control, removing sediment, turbidity, and floating material from wastewater. Adequate area and depth is essential to allow the aeration tank effluent (MLSS) to settle and compact without carryover of solids in the clarified effluent. MICRO provides clarifiers up to 54mtr.diameter in peripheral drive and up to 30mtr. In central drive both with/without scum collector.

Material of construction:

SS 304/SS316/Carbon steel

Micro Clariflocculator are combination of both flocculation as well as clarification. The clariflocculator is a chemical and physical water treatment process and it mainly consists in the removal of suspended substances. Its application is in the water treatment of surface water, industrial and municipal wastewater treatment, filtration pre-treatment, it improves the efficiency of plant and make it economical.

Material of construction: MS/ SS304/SS316

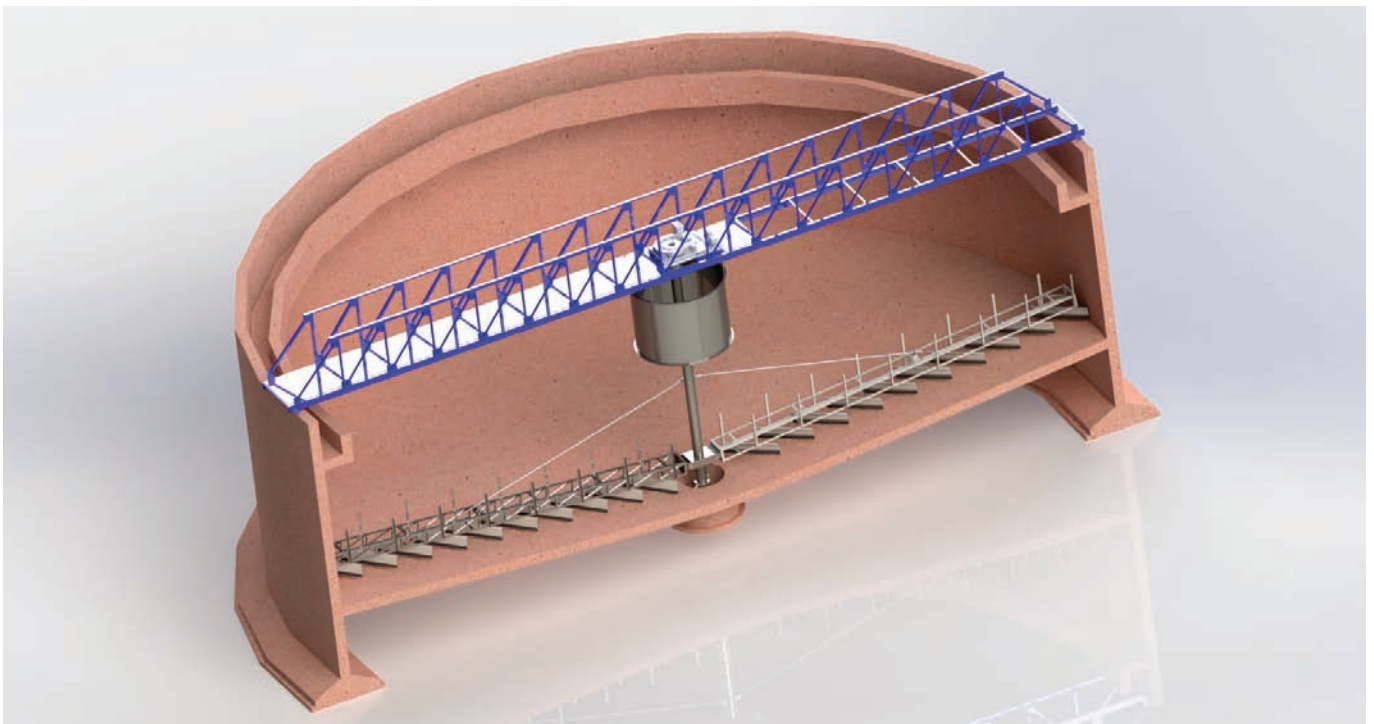

SLUDGE THICKENER

Micro made Thickeners are designed to maximize the flocculation efficiency, self-dilution and settling rates. Generally used in sewage treatment plants/ effluent treatment plants, to thicken the sludge by sedimentation of the suspended solid particle in the effluent water & to get the clarified water from the overflow

Material of construction: MS/SS304/SS316

SBR - DECANTER

The Decanter is a cost-effective solution that delivers high-quality treated water for the same price as less advanced systems. It naturally includes nutrient removal, eliminating the need for additional treatment steps. Designed for simplicity, the Decanter is easier to operate and maintain than traditional systems, ensuring reliable results even when the input varies. Its compact, space-saving design makes it suitable for facilities with limited space. Additionally, by removing more pollutants, the system is environmentally friendly, contributing to better protection of the surrounding ecosystem.

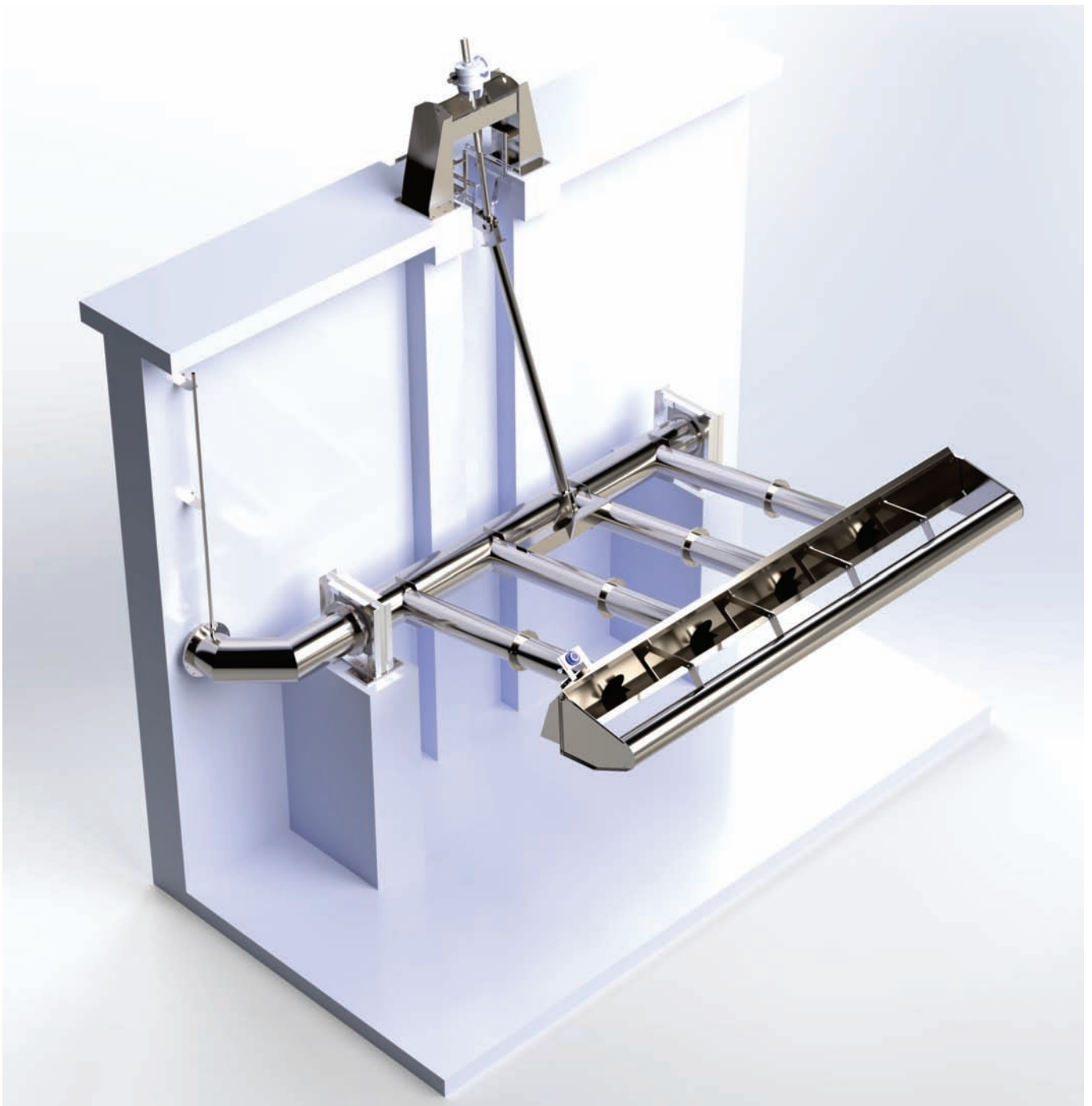

FIBER DISC FILTER

Micro Fiber Disc Filter are design for Filtration of large volume waste water for tertiary treatment. Fiber disc filter operates based on the principle of mechanical filtration. The filter consists of tightly packed fibers that create a barrier for particles larger than the spaces between the fibers. When fluid passes through the filter, the particles get trapped in the fibers, allowing only clean fluid to pass through. The efficiency of the filtration process depends on factors such as the size and density of the fibers, as well as the flow rate and pressure of the fluid. Overall, the working principle of a fiber disc filter involves separating impurities from the fluid by using a dense fiber barrier to capture particles while allowing the clean fluid to flow through

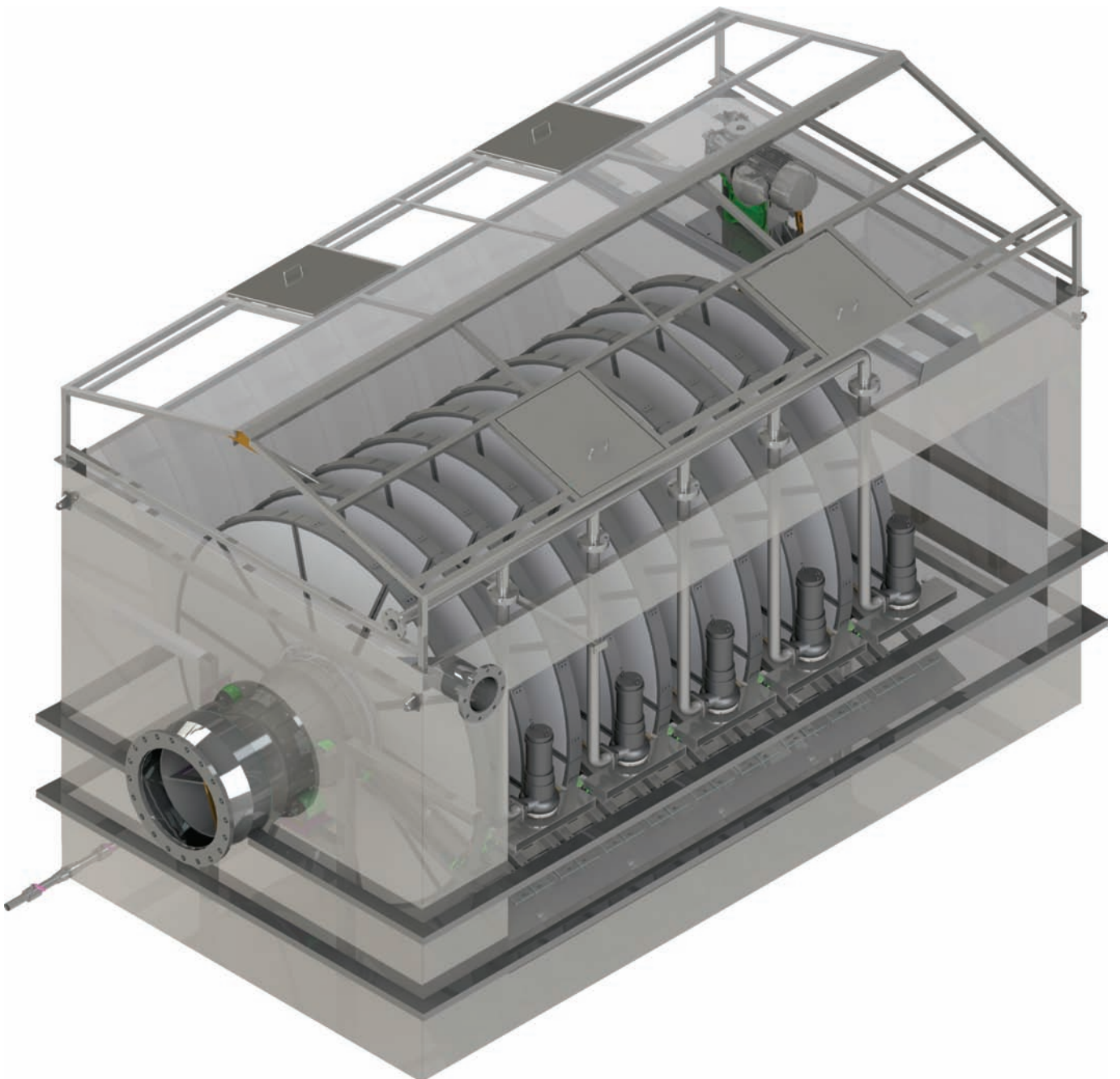

SLUDGE DEWATERING MACHINE

The 'Micro' Sludge Dewatering Machine is unique in construction and offers de-watering at a very low energy consumption with very high solid yield in dewatered sludge. The machine operates at a very low sound level with negligible vibration. It is the industry's dream machine that is easy to operate and simple to maintain.

The Machine has a unique concept of thickening and pressing in single cylinder. That's why 'Micro' Sludge Dewatering Machine can work at a very low concentration of slurry. With this feature, it can operate without any thickener. It can take slurry directly from the treatment process such as sludge sump/clarifiers/oxidation ditches and can give dewatered sludge up to 20% of solids.



SLUDGE DRYER – HOLLOW PADDLE TYPE

The Micro Sludge dryer has been designed and developed for drying of different types of sludge like biological & chemical sludge. These machines are highly efficient, mechanically agitated, indirect heating by steam or thermic fluid and it comes with Cyclone Separator and wet scrubber for environment safety. There are two counter rotating paddle shaft with uniquely designed intermeshing wedge type paddles that produce intimate mixing and self-cleaning of heat transfer surface for optimization of heat transfer resulting in minimizing the footprint of machine.

Capacity: Up to 1000 kg per hr

MOC: SS 304 and SS 316

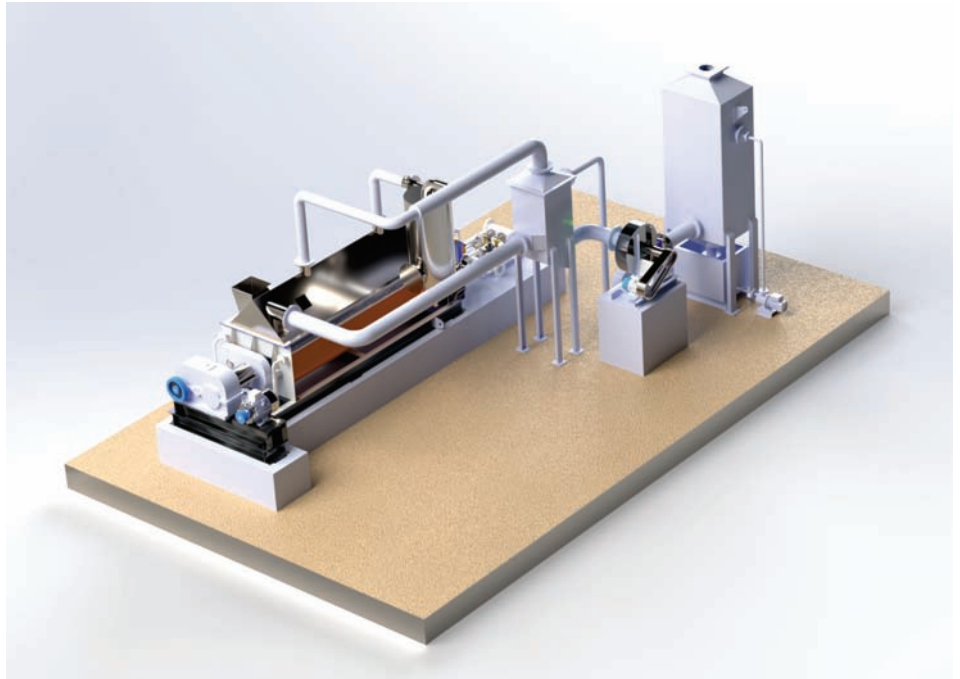

SLUDGE DRYER – BATCH TYPE

The Micro Batch Type Sludge Dryer is a compact and energy-efficient system designed for drying biological and chemical sludge. Engineered for small to medium-scale operations, it delivers consistent drying performance using an advanced electric heating system and it comes with cyclone separator and wet scrubber for environment safety, ensuring reduced sludge volume and easier disposal.

Batch Capacity: Up to 150 kg per batch

Cycle Time: Approx. 3 hours per batch

Heating System: Electric (precision-controlled)

Operation Type: Batch process

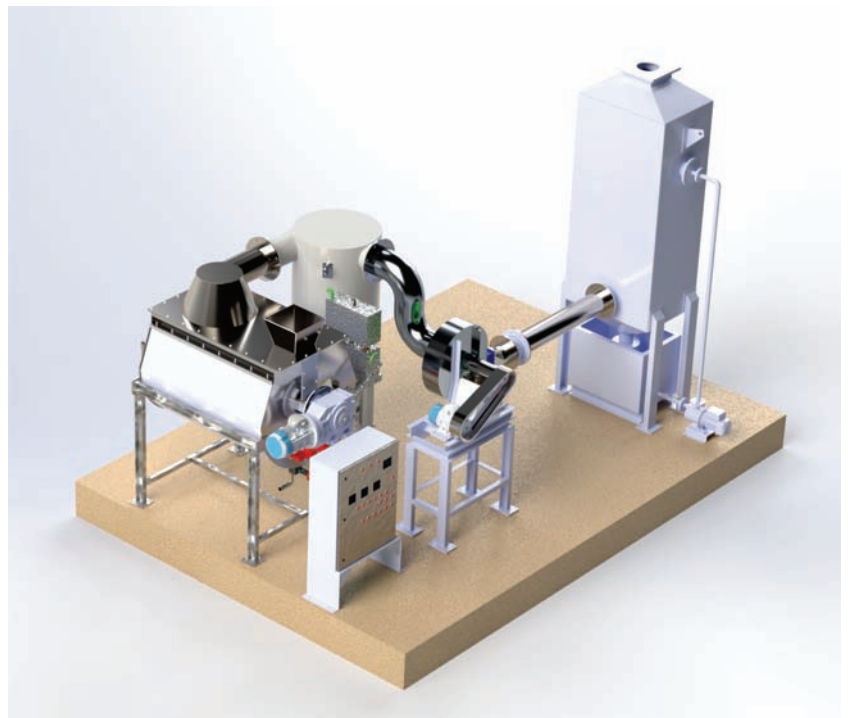

SLUDGE DRYER – SOLAR BASED

Micro Sludge dryer has been designed and developed for drying of different types of sludge paste like biological & chemical sludge. These machines are highly efficient, mechanically agitated, indirect heating by steam or thermic fluid. There are two counter rotating paddle shaft with uniquely designed intermeshing wedge type paddles that produce intimate mixing and self-cleaning of heat transfer surface for optimization of heat transfer resulting in minimizing the footprint of machine.

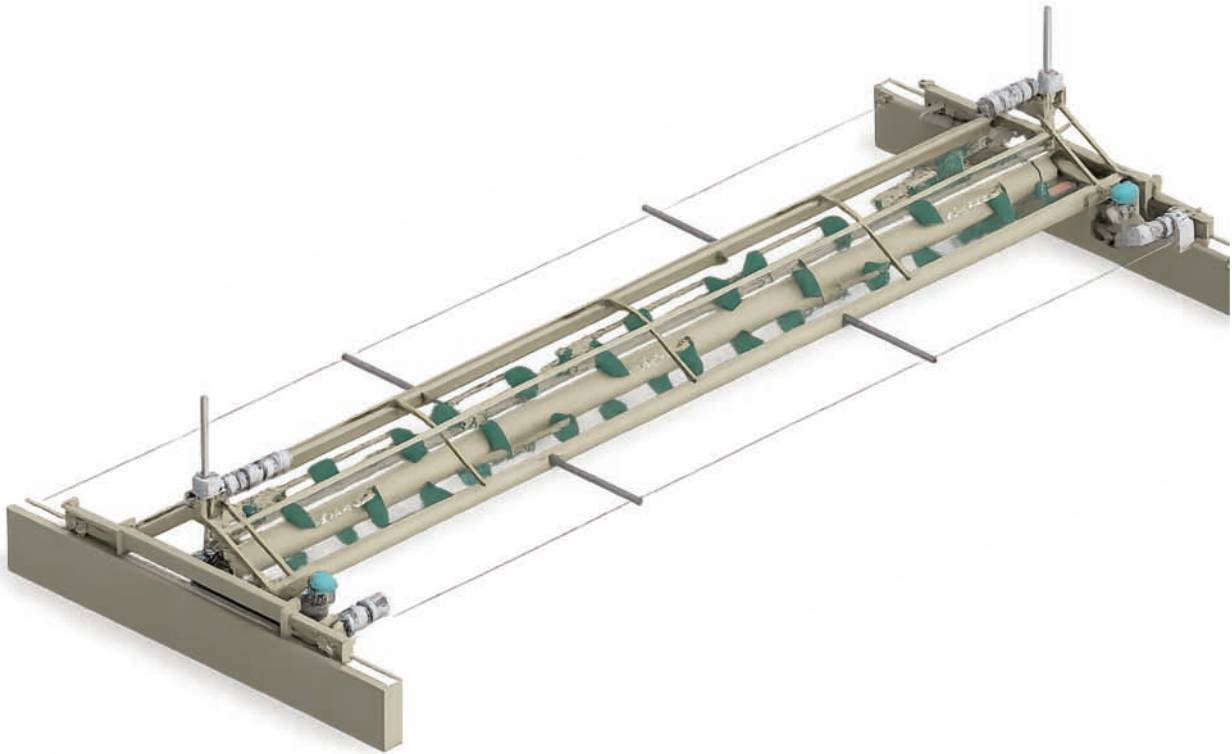

OIL SKIMMER – BELT TYPE

Oil skimmers are critical components engineered for the efficient removal of floating oil from liquid surfaces. Utilizing oleophilic materials with a preferential affinity for hydrocarbons over the underlying fluid, these systems deliver high-performance and reliable oil separation

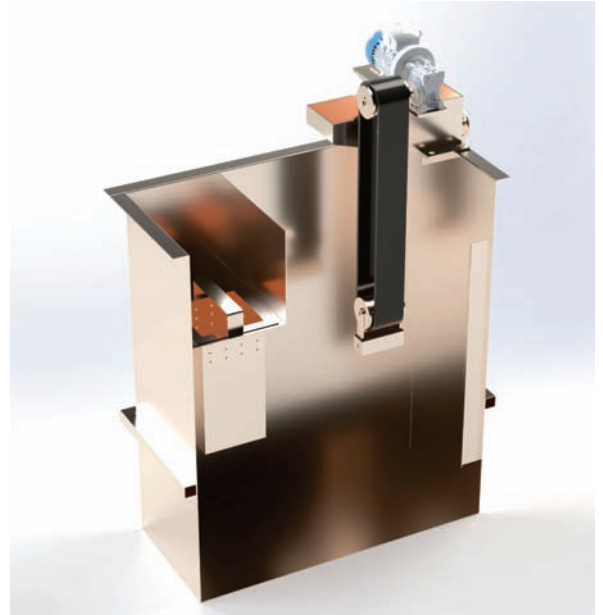

API OIL SEPARATOR

API oil separator is provided to remove the free-floating oil from waste water generated from restaurants, laundries, refineries, auto services centres etc. Free floating oil is separated from the waste water in quiescent condition offered by these types of separators. Separation of spent oil is based on theory of gravity separation. Being lighter oil floats on the surface of waste water and gets collected with help of endless chain type scrapper in a launder. A level controller is fitted to maintain the correct level of floating oil for easy collection of oil in launder.

FLOATING SCUM SKIMMER

Micro Floating suction Skimmer is a suction type skimmer used in application of bulk oil grease and scum removal from any liquid medium. This system is basically a free float skimming device which collect oil / scum by gravitational flow. Our skimmer is made of high-grade stainless-steel material to with stand high temperature and high turbidity in floating medium.



SLUDGE HOPPER

A sludge hopper is a container or vessel designed to collect, store, and sometimes transport sludge—a semi-solid by-product generated from wastewater treatment process. Typically located at the bottom of sludge thickener, dewatering units, or sedimentation tanks, the sludge hopper sloped design facilitates the gravitational flow of sludge towards a collection point. The design minimizes the need for additional mechanical process to move the sludge

Capacity Range: 20m³ to 40m³

Material of Construction: MSEP, MSGI, AND STAINLESS STEEL



LIFTING DAVIT

This is being used to lift pumps/agitators /any other equipment from any basin.

The Lifting Davit features a robust vertical base, a rotating arm, and a hand-operated winch with a gear mechanism for controlled lifting. It includes a pulley system at the end of the arm to guide the cable and secure the load. The compact and stable design makes it suitable for industrial, construction applications, where precise and safe lifting is required.

CAPACITY RANGE : Up to 400 kgs



GI RAILING FIXTURES

MTS clamp pipe fittings are produced to be used in systems such as railings, fences, shelves etc. Our pipe clamp solutions are manufactured using malleable/ductile iron and thus avoid highly undesirable effects such as breakage, cracking and deformation. All of the above fittings are galvanized to enhance corrosion resistance. The system has been designed completely on clamping screws and has the ability to be assembled in any desired form, according to the user's requirements. The assembly can be performed without the use of welding. Our model is the most suitable for 32 NB pipe (42.4 mm OD pipe)

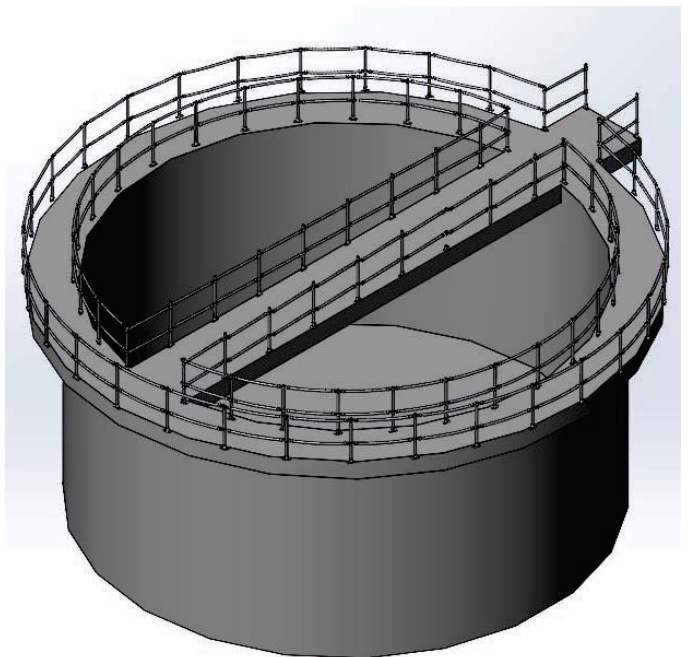
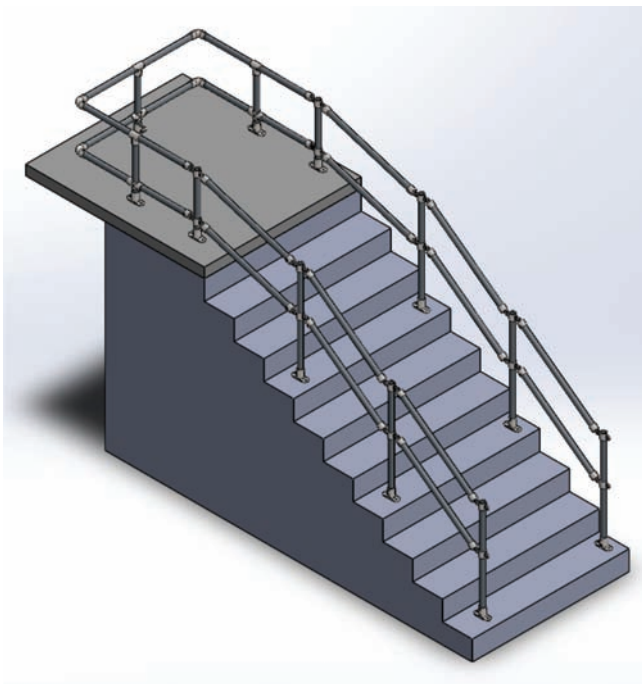

MICRO - RAETTS TURBO BLOWER

Maglev Turbo Blower

- Energy Saving >30%
- Motor Efficiency >95%
- Ultra-low noise <80dB
- Long Life >20 years
- Precision design construction
- Low operation & maintenance cost
- UPS power failure protection



AIR BEARING TURBO BLOWER

- Energy Saving >30%
- Motor Efficiency >95%
- Ultra-low noise <80dB
- Long Life >20 years
- High efficiency cooling system
- Low operation & maintenance cost
- Simple structure, no lubrication
- Frequency conversion control



AUTHORISED SALES & MARKETING PARTNER FOR INDIA

OUR INSTALLATIONS



30 MLD STP KOTA (SBR Decanter)



**ILLAHIBAGH Pumping Station,
Gorakhpur (Gates)**



**100 MLD STP JODHPUR
(Fiber Disc Filter)**



2.5 MLD STP Barwa, PHED Haryana (SBR Decanter and Step Screen)

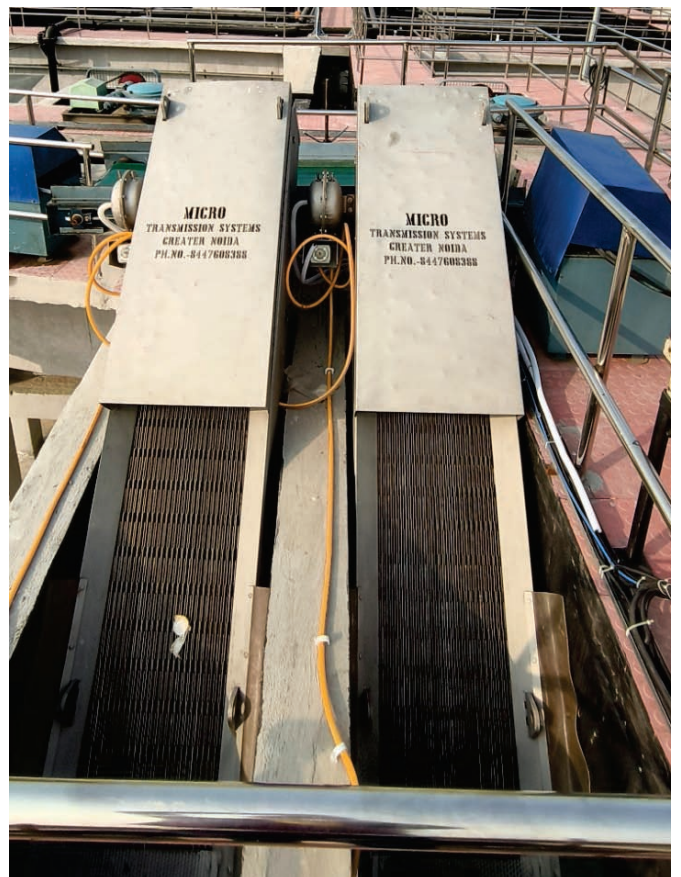

OUR INSTALLATIONS

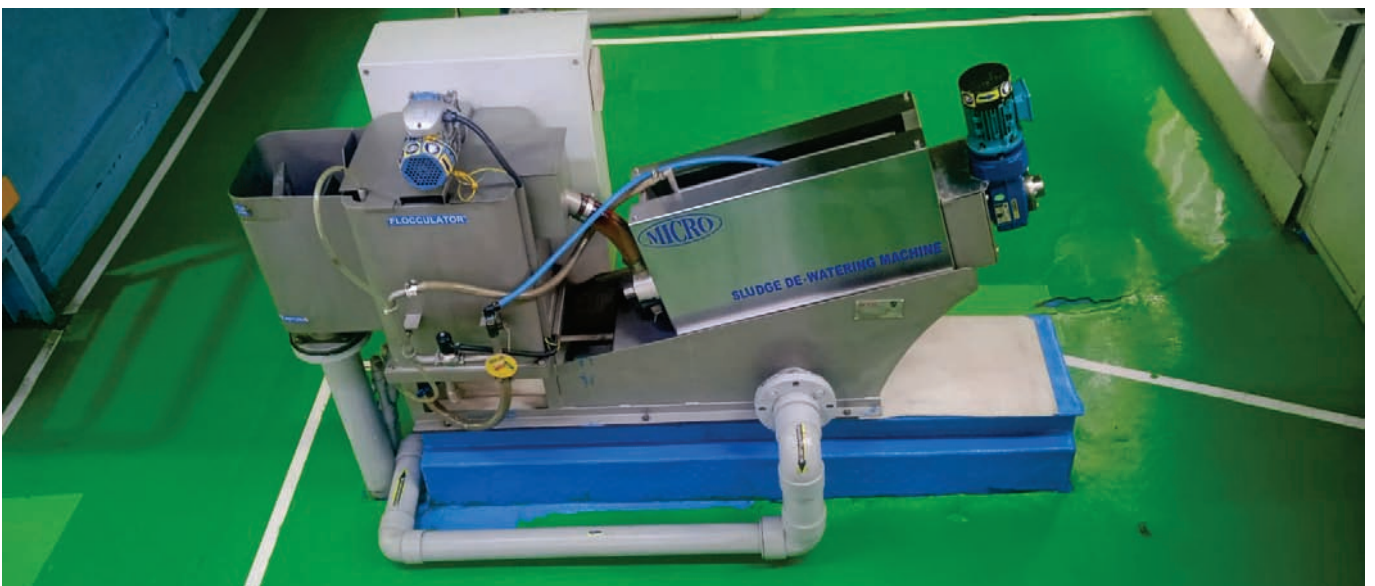

**Hero Motocorp Ltd.
(Clarifier, Paddle Dryer and Sludge Dewatering Machine)**

OUR ENLISTMENTS & CUSTOMERS



PUNJAB WATER SUPPLY AND SEWERAGE BOARD



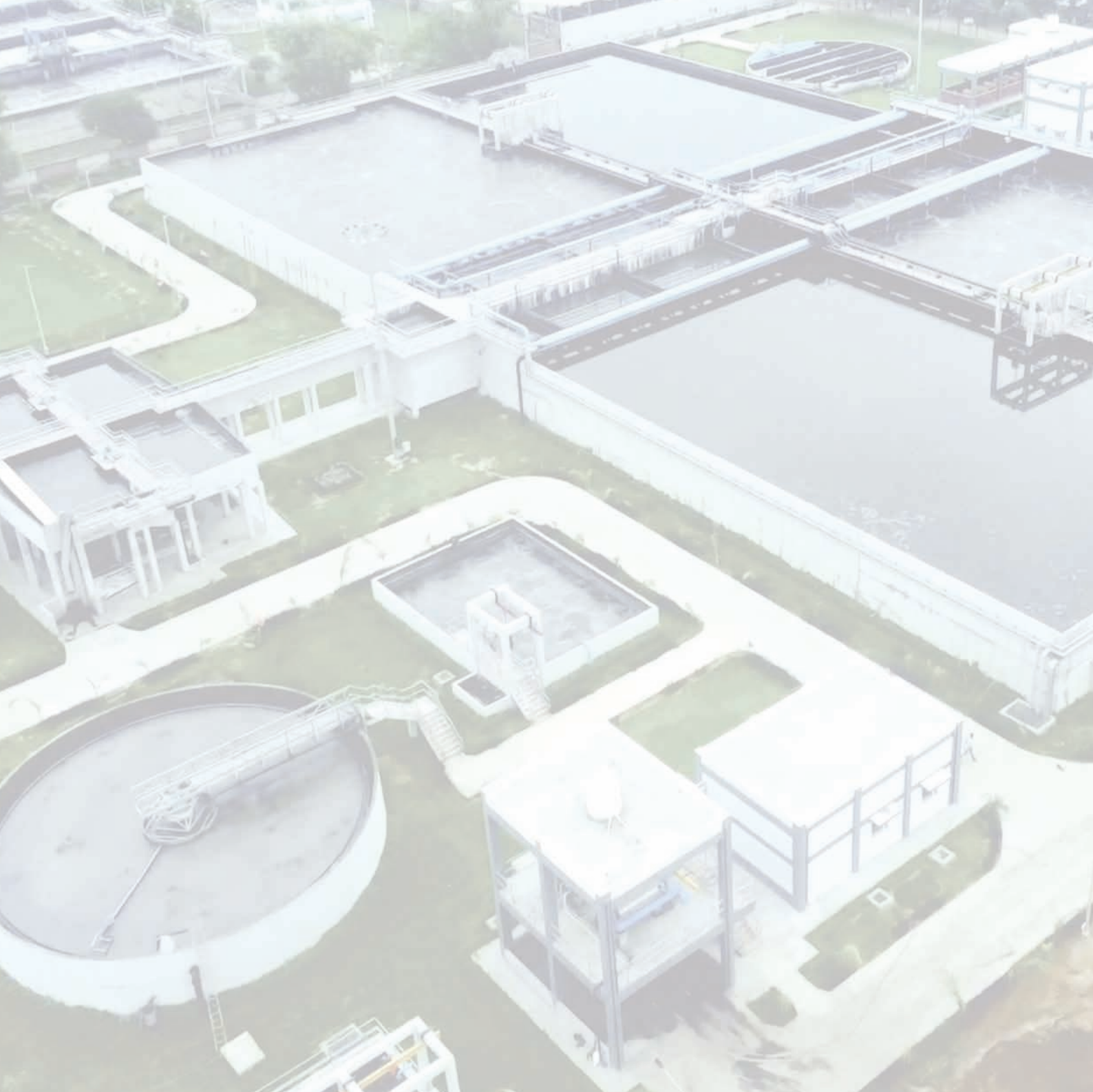

MICRO TRANSMISSION SYSTEMS



D-29, Site-B, UPSIDC, Surajpur Industrial Area
Greater Noida - 201310 (Uttar Pradesh)



+91-8447608388 , +91-9444904227
+91-9555464777 , +91-9811163168



marketing@microtransmissionsystems.com



www.microtransmissionsystems.com



Website



Digital catalogue